

GoDEX



AG4000T

HIGH-END PNEUMATIC PRINT & APPLY SOLUTIONS

Barcodes Made **Easy**

Product Specifications
AG4000T

Print & Apply Solutions

Model Name	AG-4000-400001	AG-4000-600001
Description	<p>The AG4000T line matches our industrial ZX1000i printers with high-end pneumatic tamp applicators, to label products and packages with unique, real-time data.</p> <p>AG4000s are affordable and extremely easy to install, operate and maintain. They will print and apply labels from 10x20mm up to 100x200mm to products on conveyors and in robotized systems fully automatically or semi-automatically in manual workflows. The available piston lengths are 400mm and 600mm. Options such as blow-on, roll-on and suspended heads are available to tune the AG4000T to your application.</p> <p>The applicator is very compact, comes with an air filter/separator and three external connectors: AUX (signal exchange with auxiliary system), PRINTER (signal exchange with the printer) and LIGHT (alarm light connector). The device has an extra internal port to connect options like an additional sensor in blow-on applications. The AG4000T can be operated in various modes, each allowing different patterns of communication with external PLCs and auxiliary IT systems.</p>	
Compatible Printers	ZX1000i printer series	ZX1000Xi printer series
Required printer options	Rewinder unit GP-031-Z2i005-000, GPIO module card GP-031-Z2i003-001	
Required air pressure	Min. 5 Bar	
Std. head size	100mm x 100mm (adjustable to labels from 20mm x 10mm to 100mm x 100mm)	
Opt. head sizes	20mm x 20mm up to 110mm x 200mm	
Stroke	400mm	600mm
Effective Stroke	250mm	450mm
	(The effective stroke equals the maximum allowed height difference between the products in one production batch)	
Label sizes	min 20mm x 10mm, max 110 x 200mm	
Label roll diameter	200mm standard inside the printer / 280mm optional with external holder	
Performance***	up to 30 labels/minute of 100mm x 100mm at an effective stroke of 170mm up to 60 labels-minute of 20mm x 20mm at an effective stroke of 10mm	
Supply voltage	230V (110V on request)	
Options	Application heads of any size between 20x20mm and 100x200mm; External Label roll holder for rolls up to 280mm diameter; Roll-on/Blow-on application heads; PNP photo sensor; Heavy duty floor stand components (positioners, tubes, joints, etc.).	
Recommended stand configuration:	Depending on application and local conditions	
Dimensions (400 mm stroke version)	Length	496 mm (incl. printer)
	Height	766.5 mm (incl. printer)
	Width	270 mm (incl. printer)
Weight (excluding stand assembly)	16Kg without printer / 30Kg including printer	
Certifications	The AG4000T meets the CE standards for electrical equipment.	

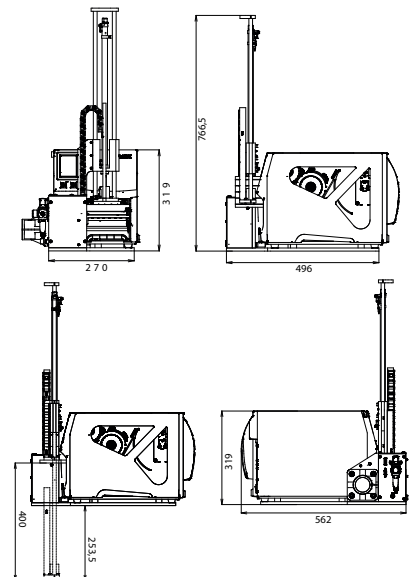

* Specifications are subject to change without notice. All company and/or product names are trademarks and/or registered trademarks of their respective owners.
 ** Minimum label length- and width compliance may depend on variables such as label material, -thickness, spacing, liner construction, etc. Godex will be pleased to test non-standard materials and critical sizes. GoDEX does not supply conveyors of any kind.
 *** The process speed depends on variables such as label size, the type and source of the data processed, stroke length (product height), required product contact time and conveyor speed.